

Tray Erector

Flexible, small and efficient



TE-740

For trays, display boxes, and display trays.

Horizontal machine function for easy access.
The tray is folded in a stationary position.
Step function for easy setting and control.

Blank erection by unique forming tool.

Unique and simple blank feed system on \emptyset -belts.

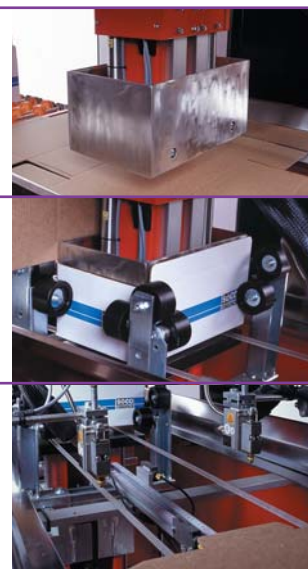

Technical specifications

Corrugated board:	A-, B-, C- and E-flute
Speed/min:	12-17 trays/minute depending of tray size
Machine dimensions	L:2000 x B:1000 x H: 1870 - see drawing below
Outfeed height:	850 +/- 100 mm
Voltage:	230/400 V, 50/60 Hz, 3-phases, zero and earth
Air consumption:	42 l free air per cycle
Air pressure:	600 kPa, min. 500 kPa
Connection:	1/2"
Power consumption:	3 kW
Net weight:	300 kg

MACHINE DIMENSIONS

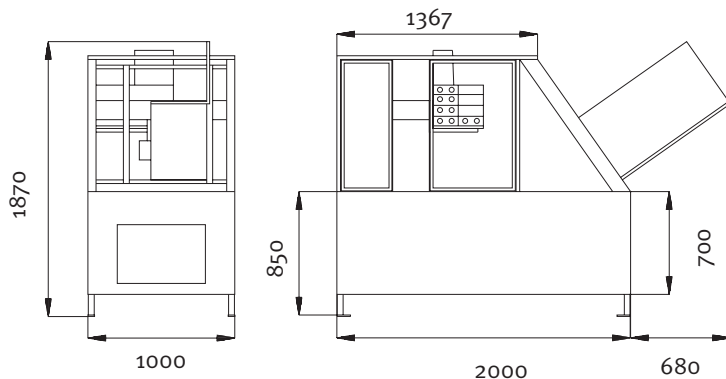

BLANK SIZES:

A	Max. 700 mm	
B	Max. 800 mm	
H	Max. 180 mm	Min. 40 mm
W	Max. 400 mm	Min. 185 mm
L	Max. 400 mm	Min. 220 mm

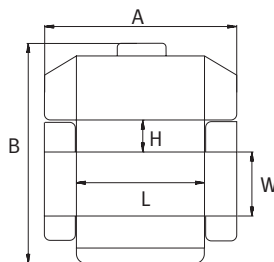

All measurements are in mm. Right to alter specifications reserved.

DIFFERENT TRAY TYPES ACCORDING TO FEFCO CODES:

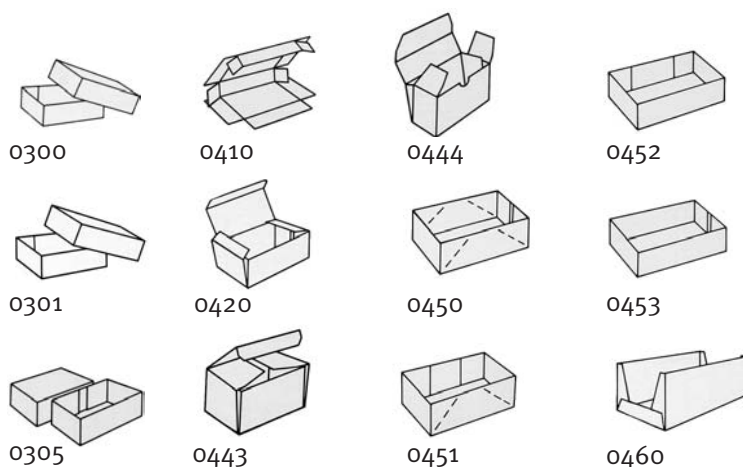

Tray Erector TE-740

The Tray erector TE-740 is a flexible and compact machine that erects display boxes, display trays and trays. Contrary to traditional tray erectors, the TE-740 has a horizontal machine function assuring easy access to all vital parts of the machine and that the box/tray leaves the machine in normal working height.

A blank feed system on \emptyset -belt moves the blank past two hot-melt guns to the forming section. The blank is formed in stationary position by means of a unique folding system consisting of an inner and an outer forming tool. The fixed inner forming tool moves down on the blank and the adjustable outer tool with forming wheels moves upwards and forms the tray around the inner tool - a simple and secure procedure.

A step function in the control system for easy machine setting and function control is included in the standard version.

The Tray Erector TE-740 is easy to operate and to adjust to different blank sizes.

SOCO SYSTEM's Total Concept.

The Tray Erector TE-740 is part of SOCO SYSTEM's modular and flexible product range.

SOCO SYSTEM's product range covers requirements from simple roller conveyors to fully automatic end-of-line systems with carton erection, pick & place, conveying, carton sealing, palletising and pallet stretch wrapping.



Head office
SOCO SYSTEM A/S
Helgeshøj Allé 16 D
2630 Taastrup
Denmark

Tel. +45 43 52 55 66
Fax +45 43 52 81 16
info@socosystem.com
www.socosystem.com