

# G220 series

the low cost solution you can count on



full-featured counting scales

**Avery Berkel**

# the low cost solution you can count on

The **G220 series of high-resolution counting scales offer high performance and ease of operation at a highly economical price.**

- ◆ **Straightforward sampling routines**  
The **G220** requires the minimum of key presses for sampling piece weights, and provides superior weighing accuracy for smaller components. A reverse sampling feature is available, which enables a count to be taken when stocktaking from full containers of a known tare weight. A piece weight can also be entered from the keyboard.
- ◆ **Highly configurable**  
The operator can set an item limit with an audible signal for counting repeat batch sizes. This function also operates in negative mode for counting out from full containers. A configurable, automatic tare feature compensates for variation in box tare weights.
- ◆ **Easy-to-read operator display**  
The large character display can be backlit, for ease of operation in dark environments.
- ◆ **Choice of power options**  
The **G220** features a rechargeable battery option, offering over two hundred hours of continuous operation when the backlit display is not in use. Alternatively, six dry cell size 'D' batteries can be installed in the lockable battery compartment, giving over 800 hours of continuous operation. When the backlight is in use, an automatic switch-off function helps to extend the battery life.

- ◆ **Ease of operation**  
A minimum weight value can be set, to provide a more accurate sample size when counting very light components. Up to 35 piece weights and pre-set tares may be stored for the most popular component lines.
- ◆ **Approved for trade**  
The **G220** has full EC approval number T5532.
- ◆ **Protection**  
An optional working cover ensures the long life of the unit and protects from everyday wear and tear.

## Specification

◆ <b>Capacities</b>	6 kg	15 kg	30 kg
◆ <b>Readability</b>	0.2 g	0.5 g	1 g
◆ <b>Readability (Approved Version)</b>	1 g	2 g	5 g
◆ <b>Internal Resolution</b> - Non-approved - Approved	7,680,000 divisions 1,530,000 divisions		
◆ <b>Displayed Count</b>	9,999,999		
◆ <b>Power</b>	12 V AC adaptor or, rechargeable battery option or, dry cell batteries		
◆ <b>Pan Size</b>	300 mm x 200 mm		
◆ <b>Options</b>	Protective cover Scoops. Head-up display.		

## Dimensions

(In millimetres)

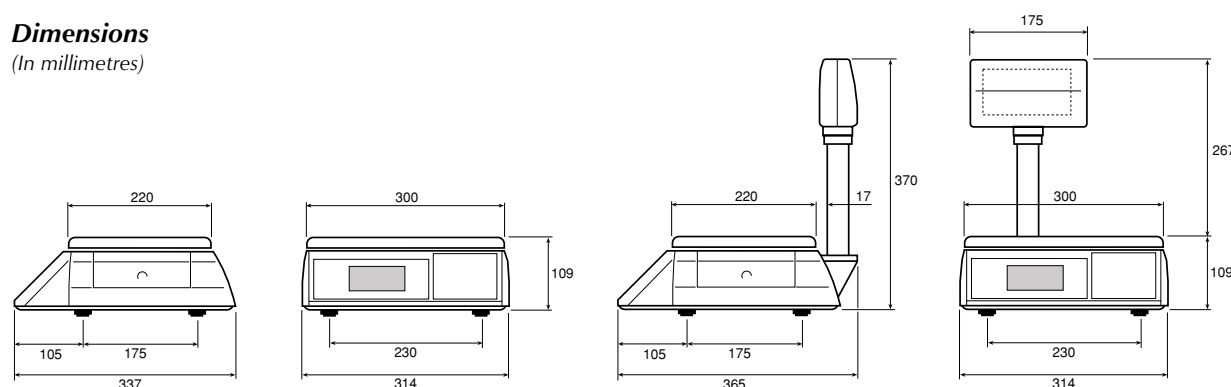

© Avery Berkel Limited 2000. All rights reserved. This publication is issued to provide outline information only which, unless agreed by Avery Berkel Limited in writing, may not be regarded as a representation relating to the products or services concerned. Avery Berkel Limited reserved the right to alter without notice the specification, design, price or conditions of supply of any product or service.

Your local distributor:

**Avery Berkel**

E mail: [info@averyberkel.com](mailto:info@averyberkel.com)  
Internet: <http://www.averyberkel.com>

Foundry Lane, Smethwick,  
West Midlands, England B66 2LP.  
Tel: +44 (0)870 90 34343 Fax: +44 (0)870 90 50085