

# WEIGH-TRONIX

## Lift Truck Scale



**LEGAL FOR  
TRADE**

**Class III Carriages**  
*(20" height)*

**Class IV Carriages**  
*(25" height)*

Improve productivity with lift truck weighing capability.

Patented all-electronic design offers accuracy, reliability and fast response.

**Class III**

- 5,000 x 5 lb
- 10,000 x 10 lb

**Class IV**

- 10,000 x 10 lb
- 16,000 x 20 lb

Choice of instrumentation



# Lift Truck Scale for ITA Class III/IV Carriages

## Robust Scale Design

The durability of Weigh-Tronix's lift truck scale is immediately apparent. The scale's patented design features a heavy-duty carriage comprised of two solid metal plates coupled together by application designed Weigh Bar® weight sensors. The inherent strength of the carriage plates allows the assembly to incorporate two huge viewing ports which provide the operator a clear line of sight to the forks.

The Weigh Bars electronically measure the load on the forks and convey this information to a summing and angle detection box. The box is constructed of stainless steel and placed between two metal plates for added protection.

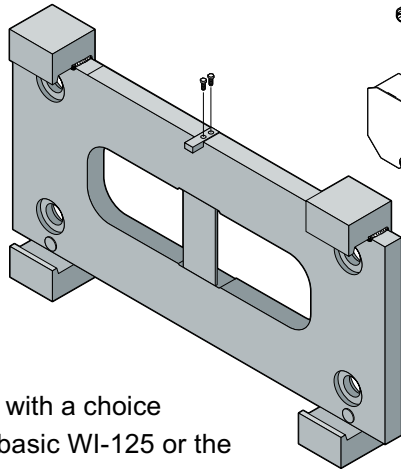

The Weigh Bar cables are enclosed within metal guards for environmental protection. Even travel stops have been designed-in to prevent forks from sliding off either end. The entire carriage assembly is primed and finished with a durable epoxy paint.

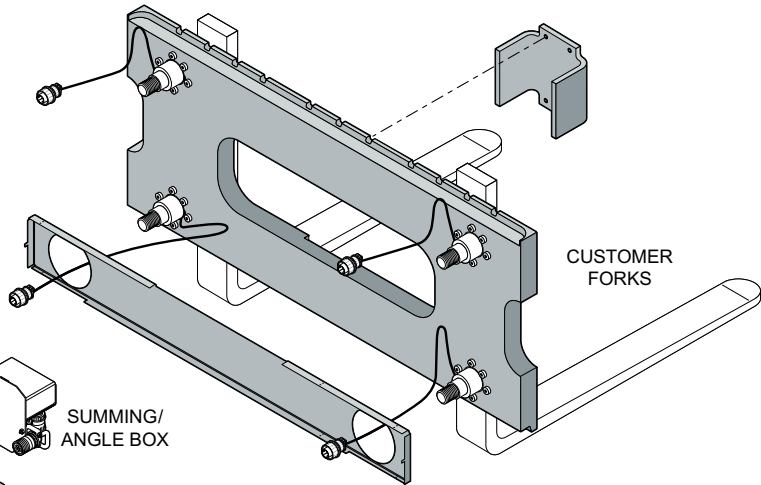

## SIMPLE INSTALLATION

*The scale carriage is hooked onto the existing lift truck carriage and secured by a centering pin and mounting clamps.*

## Instrumentation

The scale is available with a choice of two indicators, the basic WI-125 or the SimulCast™ with advanced data management.

The WI-125 is a simple no nonsense instrument.



Its LCD display provides excellent visibility in direct sunlight and has an automated backlight for low-light environments. The impact resistant enclosure features rounded corners for safety.

SimulCast has an electroluminescent multi-line display. It simultaneously displays current weight and related



data. Its database can store up to 750 records. Peripheral input devices such as scanners and bar code wands are compatible. Downloading the data can be accomplished by infrared or RF to printers, PCs, or mainframes.

## Certified Accuracy

The system's IDC (Independent Discrimination Compensation) feature ensures the system will maintain 0.1% accuracy under typical application variables: changing fork positions, unlevel wheels, or tilted mast. This is documented on the U.S. Department of Commerce, National Institute of Standards and Technology, certificate number 95-126A2.

## Weigh-Tronix

1000 Armstrong Dr.  
Fairmont, MN 56031 USA  
Telephone: 507-238-4461  
Facsimile: 507-238-4195  
e-mail: [industrial@weigh-tronix.com](mailto:industrial@weigh-tronix.com)  
[www.wtxweb.com](http://www.wtxweb.com)



## Weigh-Tronix Canada, ULC

217 Brunswick Blvd.  
Pointe Claire, QC H9R 4R7 Canada  
Telephone: 514-695-0380  
Facsimile: 514-695-6820

# WEIGH-TRONIX

Weighing Products & Systems