

Semi Automatic Carton sealer

T-2000
For uniform
Carton sizes



**Crank Handle adjustment
for carton size**



**Tape measure on legs for
easy and precise working
height adjustment**

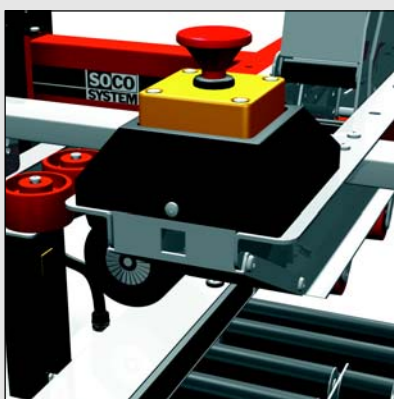

**Manual side pressure
guides and centrally
placed emergency stop**

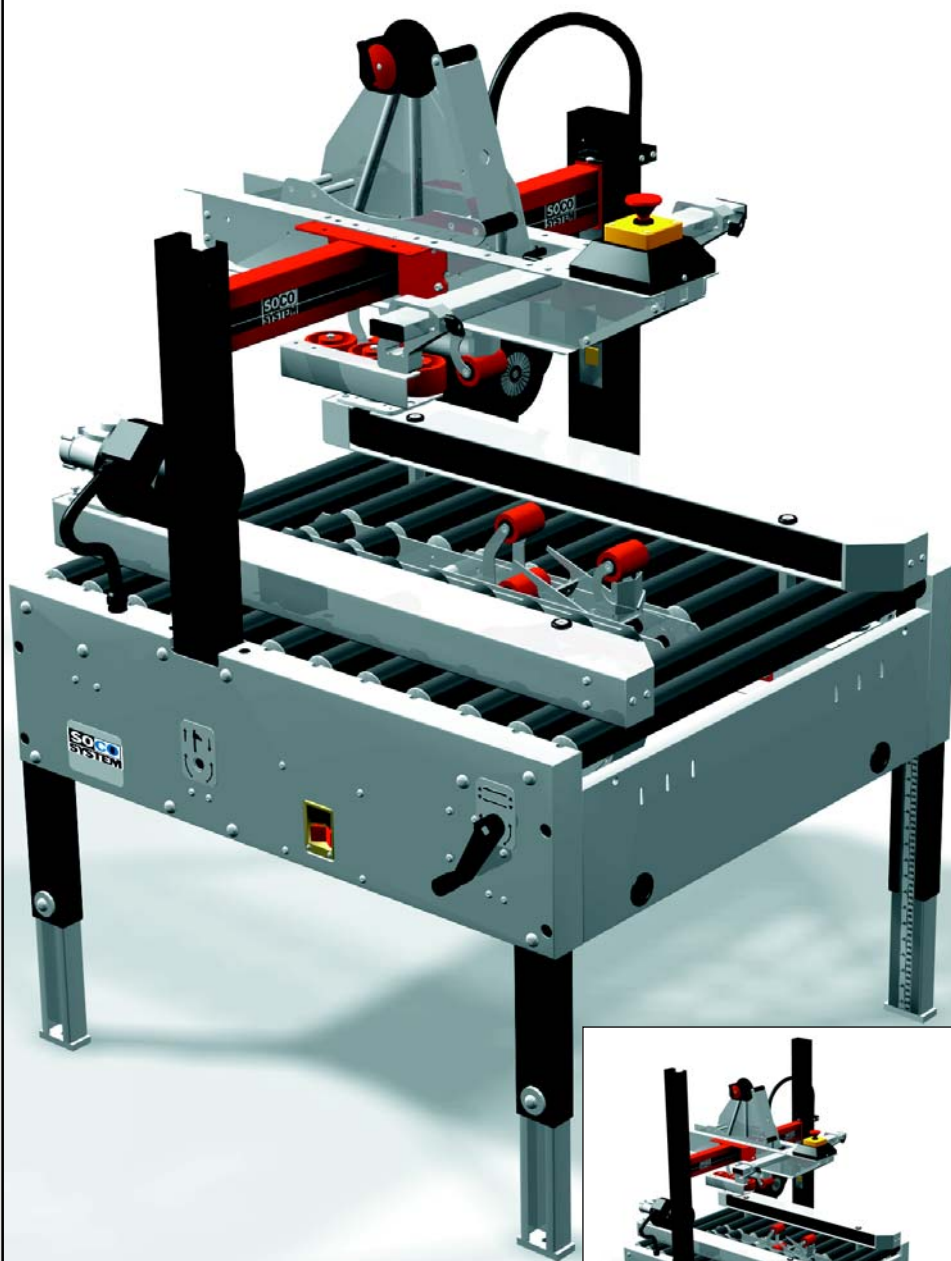

**T-2000 Maxi with high
pillars for handling of
large cartons** →

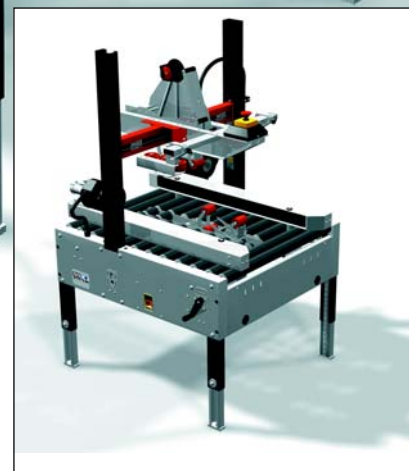

Purpose-built for “round the clock” applications. Simultaneous top and bottom sealing of uniform carton sizes.

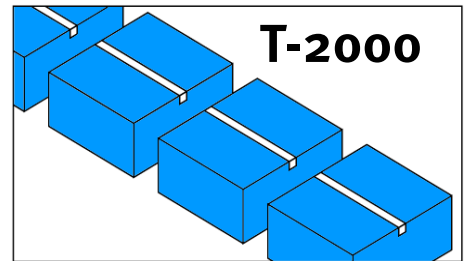

Basic models

The T-2000 is ideal for production runs of uniform carton sizes. The compact machine is available in two standard constructions, the T-2000 and the T-2000 Maxi - a wide version of the T-2000, suited for use in industries where large cartons are handled.

Both models are available with extra high pillars (see table).

The machine is easy to clean and resistant to damp and moisture.

High Quality Tape Dispensers

All SOCO SYSTEM dispensers are fitted

with an adjustable hub brake, adjustable tape roller hub, double roller units, knife guards etc. All dispensers can be fitted with a tape alarm system to monitor the sealing process.

Three types of dispensers can be used for the T-2000 series:

- 30 mm dispenser for tape ranging in width from 25-30 mm.
- 50 mm dispenser for tape ranging in width from 38-50 mm.
- 75 mm dispenser for tape ranging in width from 50-75 mm.

Features:

- Crank handle adjustment for carton size. For operation on the opposite side, just pull out the handle and place it on the other side of the machine.
- Tape measure on legs for precise adjustment of working height.
- Efficient side belt drives.
- Side pressure guides.
- Interchangeable top and bottom tape cartridge.
- Compact design.
- Extensive accessory programme from the SOCO SYSTEM CON-30 conveyor system - such as infeed and outfeed conveyor modules, packaging tables, rotary tables etc.

Comprehensive Programme

The T-2000 series forms only a small part of a comprehensive range of carton sealers and conveyor systems.

Ask for our main catalogue.

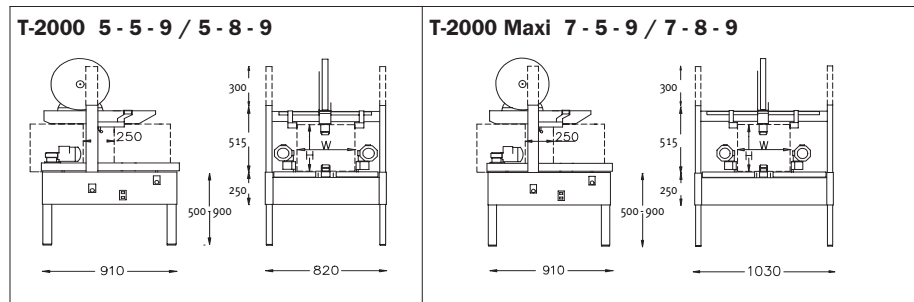

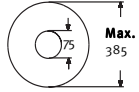
Model	Data	Carton Dimensions**			Tape overlap		Dispenser width			Capacity**	Side drives				Shipping carton dimensions			Weight kg	
		Length	Width	Height	70	50	25-30	38-50	50-75		50	80	200/400	50	80	200/400	200/400		80
T-2000 5-5-9	Max. Min.	∞	520 90	520 90/140*	●	●	●	●	●	Max. 30/min.	●	●	●	●	1010	870	885	150	
T-2000 5-8-9	Max. Min.	∞	520 90	820 90/140*	●	●	●	●	●	Max. 30/min.	●	●	●	●	1010	870	1190	155	
T-2000 Maxi 7-5-9	Max. Min.	∞	720 130	520 100/150*	●	●	●	●	●	Max. 30/min.	●	●	●	●	1010	1080	885	160	
T-2000 Maxi 7-8-9	Max. Min.	∞	720 130	820 100/150*	●	●	●	●	●	Max. 30/min.	●	●	●	●	1010	1080	1190	165	
General	Electrical equipment: 3x230/400 V 50-60 Hz or 3x415/460 V 50-60 Hz Connected load 0,3 Kw Other specifications available on demand.				Taperoller dimensions: 														

- Standard
- Optional

All measurements are in mm.
Right to alter specifications reserved.

* Without and with side pressure rollers.

** Depending on the quality, construction and size of the box.

SOCO SYSTEM A/S

Helgeshøj Allé 16 D . 2630 Taastrup . Denmark
Tel. +45 43 52 55 66 . Fax +45 43 52 81 16
info@socosystem.com
www.socosystem.com