

Semi Automatic Carton sealer - with top and bottom drive

T-2002
For uniform
Carton sizes

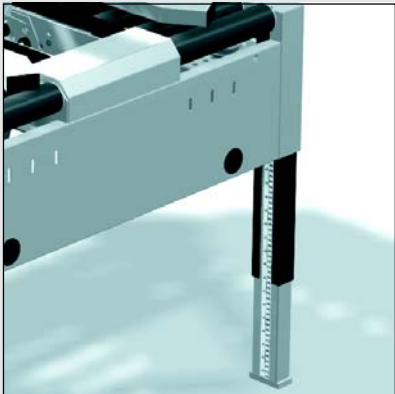

**Crank Handle
adjustment for carton
size**



**Tape measure on legs for
easy and precise working
height adjustment**

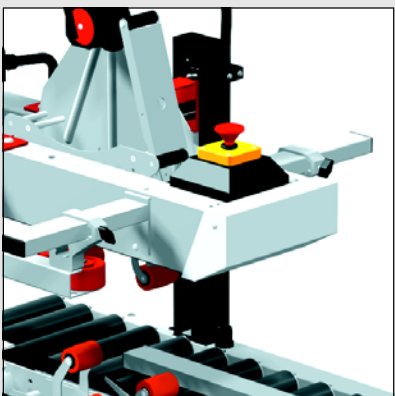

**Manual side pressure
guides and centrally
placed emergency stop**

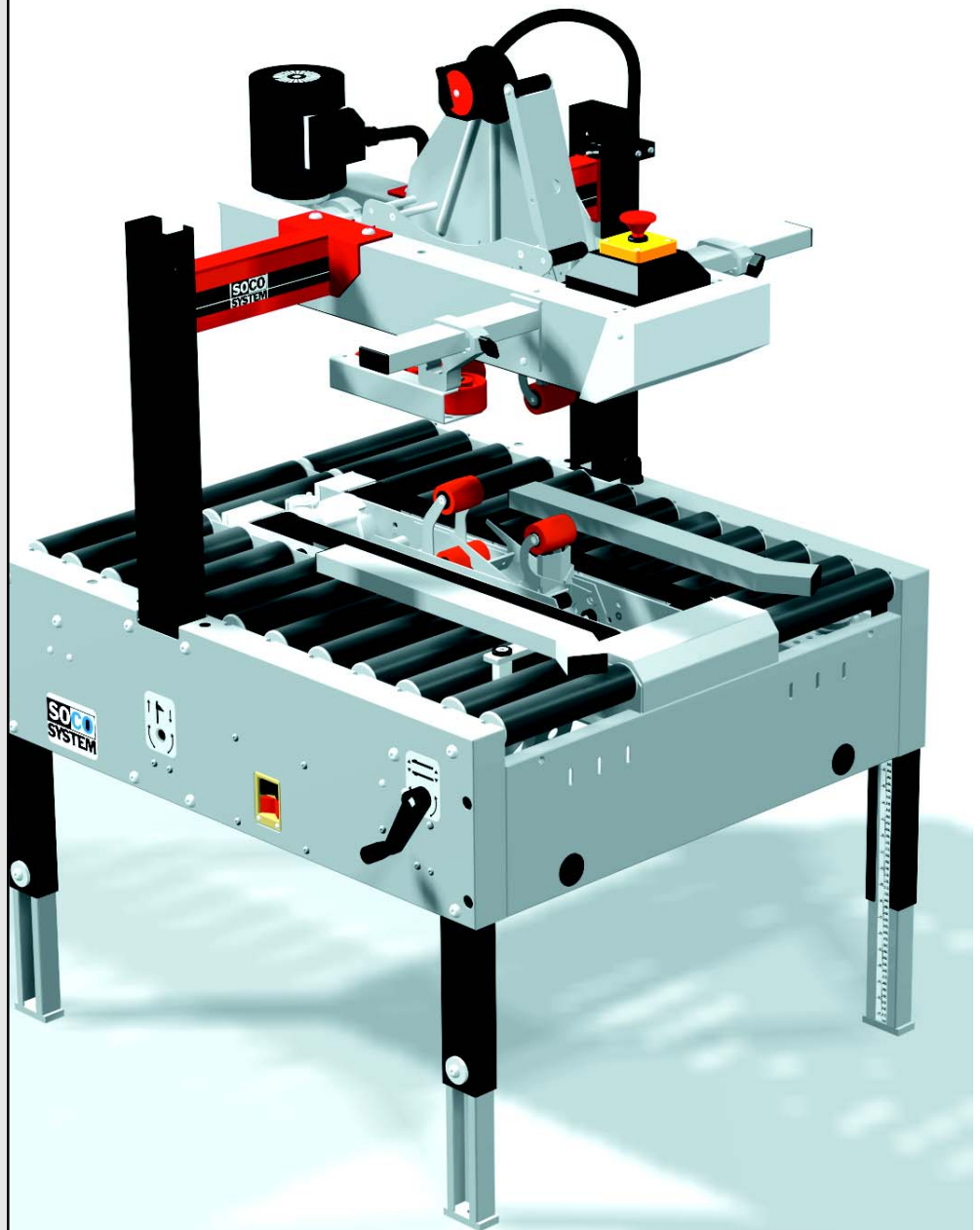

**SOCO
SYSTEM**

T-2002

Special model with Top and Bottom drive. Specially suitable for over-filled and tall, narrow or short cartons.

Features:

- Crank handle adjustment for carton size. For operation on the opposite side, just pull out the handle and place it on the other side of the machine.
- Tape measure on legs for precise adjustment of working height.
- Efficient top and bottom belt drive
- Side pressure guides.
- Interchangeable top and bottom tape cartridge.
- Compact design.
- Extensive accessory programme from the SOCO SYSTEM CON-30 conveyor system - such as infeed and outfeed conveyor modules, packaging tables, rotary tables etc.

Comprehensive Programme

The T-2000 series forms only a small part of a comprehensive range of carton sealers and conveyor systems. Ask for our main catalogue.

Model T-2002 5-5-9



Model T-2002 Maxi 7-5-9



Model T-2002 5-8-9

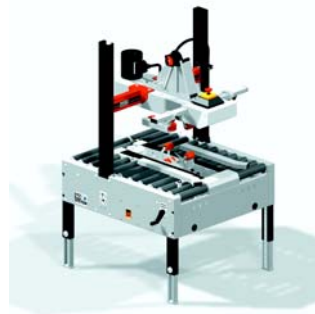

Model T-2002 Maxi 7-8-9



T-2002 5 - 5 - 9 / 5 - 8 - 9		T-2002 Maxi 7 - 5 - 9 / 7 - 8 - 9											
Model	Carton Dimensions*			Tape overlap	Dispenser width			Capacity*	Side drives	Shipping carton dimensions			Weight kg
	Length	Width	Height		70	50	25-30			38-50	50-75	Length	
T-2002 5 - 5 - 9	Max. ∞ Min. 160	500	500	● ● ● ● ●	● ● ● ● ●	Max. 30/min.	●	●	1010	870	885	165	
T-2002 5 - 8 - 9	Max. ∞ Min. 160	500	800	● ● ● ● ●	● ● ● ● ●	Max. 30/min.	●	●	1010	870	1190	168	
T-2002 Maxi 7 - 5 - 9	Max. ∞ Min. 160	700	500	● ● ● ● ●	● ● ● ● ●	Max. 30/min.	●	●	1010	1080	885	168	
T-2002 Maxi 7 - 8 - 9	Max. ∞ Min. 160	700	800	● ● ● ● ●	● ● ● ● ●	Max. 30/min.	●	●	1010	1080	1190	175	
General	Electrical equipment: 3x230/400 V 50-60 Hz or 3x415/460 V 50-60 Hz Connected load 0,3 Kw Other specifications available on demand.			Taperoller dimensions: Max. 385									

- Standard
- Optional

All measurements are in mm. Right to alter specifications reserved.

* Depending on the quality, construction and size of the box.

SOCO SYSTEM A/S

Helgeshøj Allé 16 D . 2630 Taastrup . Denmark
Tel. +45 43 52 55 66 . Fax +45 43 52 81 16
info@socosystem.com
www.socosystem.com