

Avery Weigh-Tronix

Pallet Truck Scale

Maximize efficiency by transporting and weighing loads in one easy step.

Combines the legendary durability of Raymond hand trucks with the consistent weighing accuracy of Weigh-Tronix electronic scales.

*Low profile
3" high*

- Heavy-duty construction – Smooth, precise handling.
- Commercial trade approved-buy or sell based on recorded weight.



**LEGAL FOR
TRADE**



The Pallet Truck Scale combines practical simplicity and heavy-duty construction with the added efficiency of an on-board weighing system. It eliminates wasted steps and streamlines manual loading or transfer operations. Low maintenance and high reliability are basic design characteristics you can count on for trouble-free performance, year after year.

The Raymond Corporation invented the hydraulic hand truck in 1929. Today, almost 75 years later, Raymond continues to manufacture the finest, most durable hand truck available.

Weigh-Tronix was one of the early pioneers that brought about the electronic weight measurement revolution. Since the early 1970s, our innovative designs have yielded better weighing solutions that are being used in applications around the globe.

Pallet Truck Dimensions —

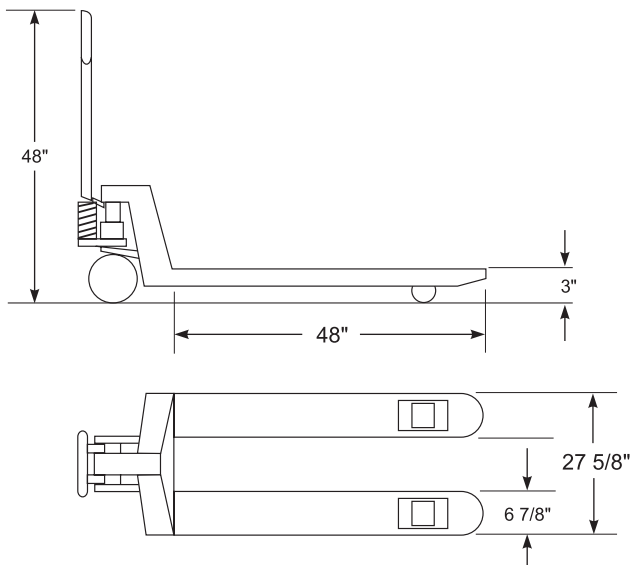

Pallet Truck Features —

- Fixed pushrods machined from solid steel – no adjustments required
- Pump is engineered with fewer parts and specially designed seals for greater reliability
- Corrosion resistant brass fittings at all pivot points
- Simple lubrication with 10 easily-accessible grease fittings
- Reinforced tow bar shoulder reduces stress on the truck's lower tow foot
- Smooth lifting and lowering action with conveniently placed fingertip controls

Weigh-Tronix Scale Features —

- 5,000 x 10 lb weighing
- Legal for trade accuracy
- Uses four legal-for-trade environmentally sealed weight sensors and the popular WI-125 legal-for-trade weight indicator. This indicator is simple to operate and the LCD digits have backlighting for low light environments.
- On-board rechargeable battery provides up to 50 hours of continuous power. The battery life with a printer will be less and is dependent on print format and utilization. Low voltage detection provides auto shut down. Optional charger recharges battery to full power in 4.5 hours.



AUTHORIZED DISTRIBUTORS

Ask the experts.

Weigh-Tronix distributors are complete support centers, providing needs assessment, technical information, product sales and service. Their experience is a valuable resource that is readily available to you. We recommend you consult these knowledgeable industrial applications specialists for all of your weight measurement needs.

Please call us or visit
www.wtxweb.com
for your nearest
Weigh-Tronix distributor.

Avery Weigh-Tronix

Fairmont, Minnesota U.S.A.
USA Toll-Free: 800-368-2039
USA Phone: 507-238-4461
www.wtxweb.com

Pointe Claire, Quebec Canada
CAN Toll-Free: 800-561-9461
CAN Phone: 514-695-0380
www.weigh-tronix.ca

7/03 ptrk_L_p65 – C&D PN09738-0018D e1 Printed in USA
Weigh Bar® is a registered trademark of Weigh-Tronix Inc.

